

The image is a promotional advertisement for Philips 3D printed lighting. It features a modern, industrial-style interior with a dark metal frame and large glass panels. In the background, a living area is visible with a fireplace, two leather armchairs, and a bed. Two black, 3D printed pendant lights hang from the ceiling. To the right, three wooden shelves are suspended from the ceiling, each holding a green plant. The floor is made of dark wood. The overall aesthetic is contemporary and eco-friendly.

**PHILIPS**

3D Printed Lighting

# 3D Printed Lighting

Tailor-made lighting for a circular economy



# Contents

Introduction	3
Decorative suspended	9
Functional suspended	17
Projectors	18
Ceiling luminaires	20
Downlights	22



Signify offers its customers the opportunity to design and adapt their own custom lighting, which is then printed in 3D. Our service simultaneously saves on time, energy and waste during manufacturing, as well as packaging and transport. 3D printing paves the way for more innovative designs, with different shapes and more complex colours. All of our 3D printed Philips lights are designed with circularity in mind, being fully recyclable.



## Sustainable lighting for the circular economy

We are firmly committed to lowering our carbon footprint. Our 3D printed and 100% recyclable lights reduce your environmental impact. We use 100% recyclable polycarbonate and do not use screws or paint. Our concept allows new fixtures to be printed from old materials.

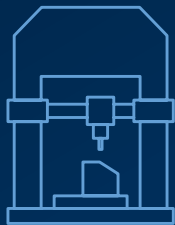

## A tailor-made design

Whether you are looking for luminaires of a certain colour, or of a certain size or cut-out, we have the solution. We offer you endless combinations of shapes and lighting options. Functional and decorative designs go hand in hand to achieve the desired effect.



## Quality lighting you can count on

As a global leader in lighting, we develop, design, manufacture and market innovative and energy efficient lighting products, systems and services. Our LED lights use quality materials and meet the high quality you have come to expect from a Philips lighting product.

# Reduce your waste and your carbon footprint

How can 3D printed lighting help you reach your sustainability goals?

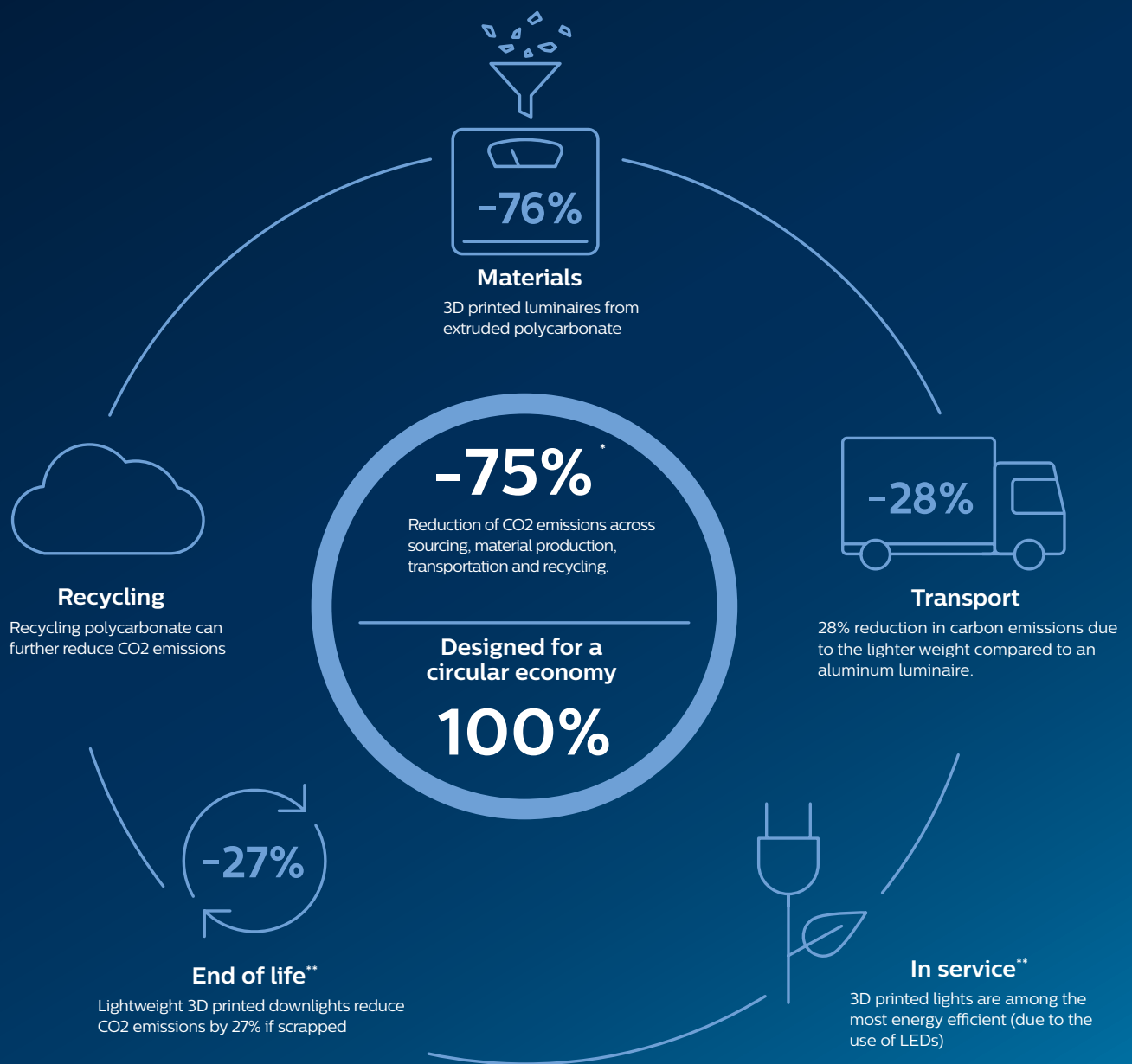

\* Assessment of the impact of the IPCC 2013 GWP 100 carbon footprint.

\*\* The use phase, although having the greatest impact, has been excluded, as it is similar between the 2 types of downlights. Data based on comparison between a traditionally produced die-cast downlight with a 3D printed polycarbonate downlight. Data for other products will vary.

# Recycling,

## How does it work?

### **Durable by default**

We have developed a manufacturing method that is both flexible and sustainable through the use of a fully recyclable polycarbonate. This enables you to quickly design or modify your lights according to your needs. At the end of their life, your equipment / materials are recycled and reused / remelted to produce new lighting.

This intelligent modular design of the luminaires allows us to extend their lifespan and reduce our carbon footprint by up to 75% compared to traditional luminaire production.

So, from design to production, the waste of resources is minimal because we recycle almost all of the fixtures, produce only the quantity strictly necessary and do not use screws or paint.







# 3D Printing, How does it work?

## **A tailor-made identity for all.**

3D printing involves depositing a recyclable polycarbonate thread in a predetermined shape and thus shaping a form.

In our luminaires we will print the luminaire body with the parameters chosen by the customer and associate it with an LED module whose technical characteristics have been selected (flux, dimming, colour temperature, etc.) as we would that of a traditional lighting fixture. The creation and customisation of lighting is done on an intuitive online configurator where you will choose the type of lighting (ceiling, recessed, projector), its colour, its opacity and its texture, so that you can shape a unique identity for an unparalleled customer experience.

**[www.tailored.lighting.philips.com](http://www.tailored.lighting.philips.com)**

# A wide choice of finishes...

23 Essentials



5 Colours



4 Transluents



7 Metallics



## ...and textures at your disposal

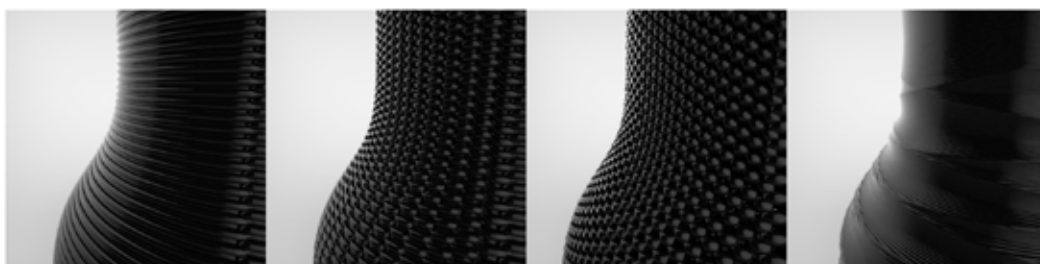
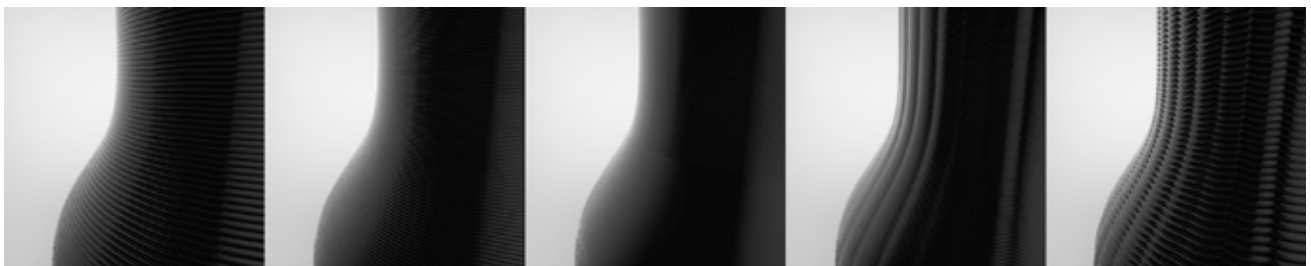



# Our decorative Suspended



## RD Series

Decorative suspended Ø 179mm to 204mm

A warm atmosphere thanks to its 7 original shapes and its variety of textures and finishes with a combination of 28 colours (translucent, pop, metallic and matte) and 11 material effects to play with E27 socket, lamp not included

- Supplied with a 175 cm or 300 cm cable
- Depending on the shape: diameter 179 mm to 204 mm, height 147 to 166 mm
- Recyclable polycarbonate

[RD Series Configurator](#)





# Original Series

Decorative suspended Ø 300 to 500 mm

- 300 mm to 500 mm diameter (depending on shape)
- E27 socket to add the lamp of your choice
- 3 shapes available in 2 sizes (M and L)

[Original Series Configurator](#)





“Personalise the interior and exterior  
of lighting thanks to the **Double Series**”



Double Arc



Double Cone



Double Dome



## Double Series

Decorative suspended Ø 300 to 450 mm

- 300 mm to 450 mm diameter (depending on shape)
- Customize both the inside and the outside of your pendant light from a wide choice of colors and textures
- 3 shapes available

[Double Series Configurator](#)



Double Series  
Configurator





# Cord Series

## Decorative Suspended

- A minimalist design to highlight your decorative E27 lamps
- Choose between 3 sizes, 10 satin or metallic colours and 8 textures

[Cord Series Configurator](#)





# Industrial Series

Decorative suspended Ø 200 to 450 mm

- Opaque or transparent materials in a wide choice of textures
- A wide variety of optical configurations with the possibility of customizing the reflector
- LED lighting modules from 1700 to 8000 lumen

[Industrial Series Configurator](#)





3D Printed Lighting





## BA and BA series large

Decorative Suspended Ø 415 mm

- A wide variety of optical configurations and the possibility of customising the reflector
- LED lighting modules from 1700 to 8000 lumen
- Opaque or transparent materials in a wide choice of textures

[BA Series Configurator](#)

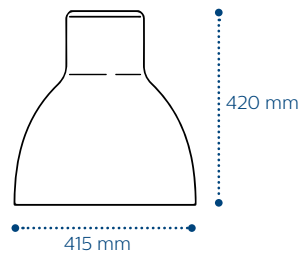

Model BA large

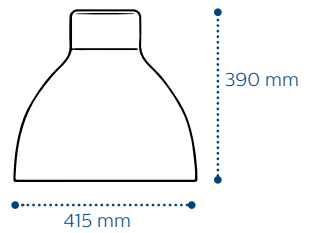

Model BA





DOZIJNEN	13
BOUWKASTEN	12,14
SPIEGELKASTEN	29
BERTEGELS	25-28
& TOILETTEN	29-30

**ACTIE** 10

**ACTIE** 12

**ACTIE** 11

**ACTIE** 14

ONS SEIZOEN  
49.99

ONS SEIZOEN  
willbert magle  
79.99

MAG X

ONS SEIZOEN  
VOOR DE MAKERS  
peukin

# Our functional suspended

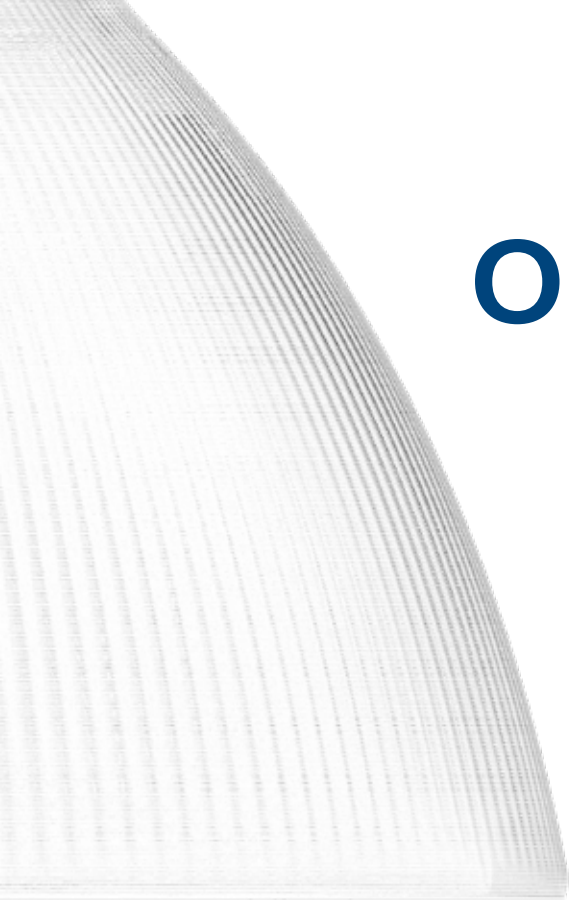

## PM Series

Functional suspended  
Ø 400 to 500 mm

- A wide variety of optical configurations and the possibility of customising the reflector
- LED lighting modules from 1700 to 8000 lumen
- Opaque or transparent materials in a wide choice of textures

[PM Series Configurator](#)



# Our projectors for track lighting

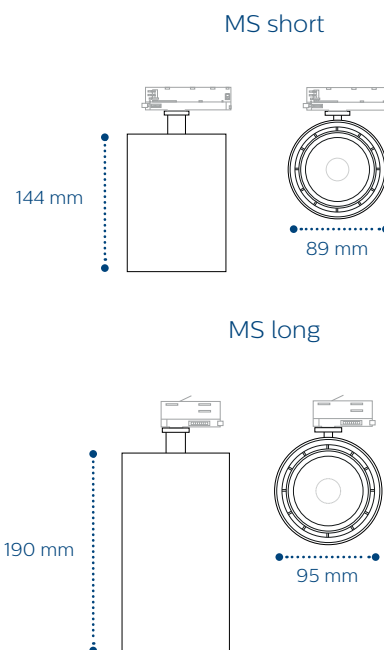

## MS Series

Efficient and elegant projectors

- Equipment that adapts to your preferences
- Several hinges and LED module designs available
- Dedicated colours for retail lighting (FreshFood, Premium White, FreshFood Meat, etc.)



# KT Series

## Functional lighting

- Great flexibility for track lighting installations
- Track, suspended or ceiling options
- Diameter 175 mm
- Flux of 1100, 2000 to 3000 lumen, in 3000K and 4000K
- Available in IRC80 and IRC90
- Optic options available (UGR19 optics)
- Transparent PCC diffuser IP54, Opal PCO diffuser)

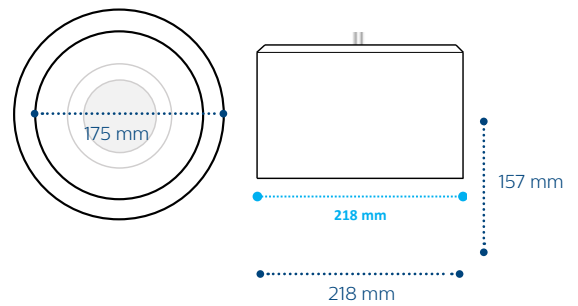

[KT Series Configurator](#)





# TT Series GreenSpace PerfectFit your tailor-made downlight

## Create your own PerfectFit

Philips 3D printed luminaires are the perfect quick & easy retrofit solution. With seamless integration guaranteed, our 3D printed downlights save you a lot of hassle and money right from the start. We print a complete downlight that is fully adapted to your dimensions, so you don't have to look for an adapter collar or halo ring to install the luminaire on the ceiling.

## The advantages of this range are immense

No more wasting time searching catalogues for compatible downlights and adapters, simply configure the ideal downlight according to the existing diameter. Installation is faster, it fits perfectly and does not require any additional parts to compensate for the space between the product and the cut-out hole. The final result is seamless, as the luminaire is perfectly integrated into the existing ceiling with no double bezel or differing colours.





## Six steps for a quick and easy retrofit

With PerfectFit, you simplify your retrofit projects in just six steps:

- 1 Measure the diameters of the recess holes in the ceiling
- 2 Configure your downlight in 30 seconds using our online configurator (link below)
- 3 When you are ready, hit 'Request Quotation'. You will receive a copy of the quotation request and one of our Philips colleagues will be in touch with your quote soon
- 4 We print your custom downlights
- 5 We deliver your downlights
- 6 Install your lights in 2 minutes

[PerfectFit Configurator](#)



# PerfectFit

## Downlight

- Printing dimensions from 150mm to 280mm diameter
- 800 lumen versions available in cutouts up to 195mm diameter
- 3 colour options



interact  
ready.

---

## Benefits of a tailor-made downlight

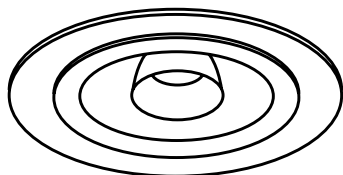

### Standard Downlight

- Unsightly double collar to ensure fit
- Risk of colour difference
- Difficult adjustments during installation

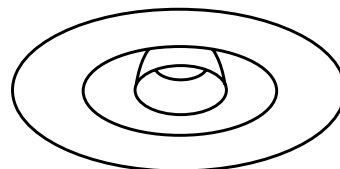

### GreenSpace PerfectFit 3D Printed Downlight

- Easy configuration of the luminaire to the right dimensions
- Clean aesthetic without colour variation
- Quick installation and perfect adjustment to the existing cut-out hole

## Lightweight for easy installation

620 g for a TT200 3D printed model against nearly 1kg for a comparable product using a die-cast aluminum housing.

## Sustainable with a reduced carbon footprint

75%\* savings on CO2 emissions for the extraction of raw materials, production and transport.

\* Data based on comparison between the housing and heat sink of a 3D printed downlight and the housing of a traditional die-cast aluminum downlight. Data for other products vary.

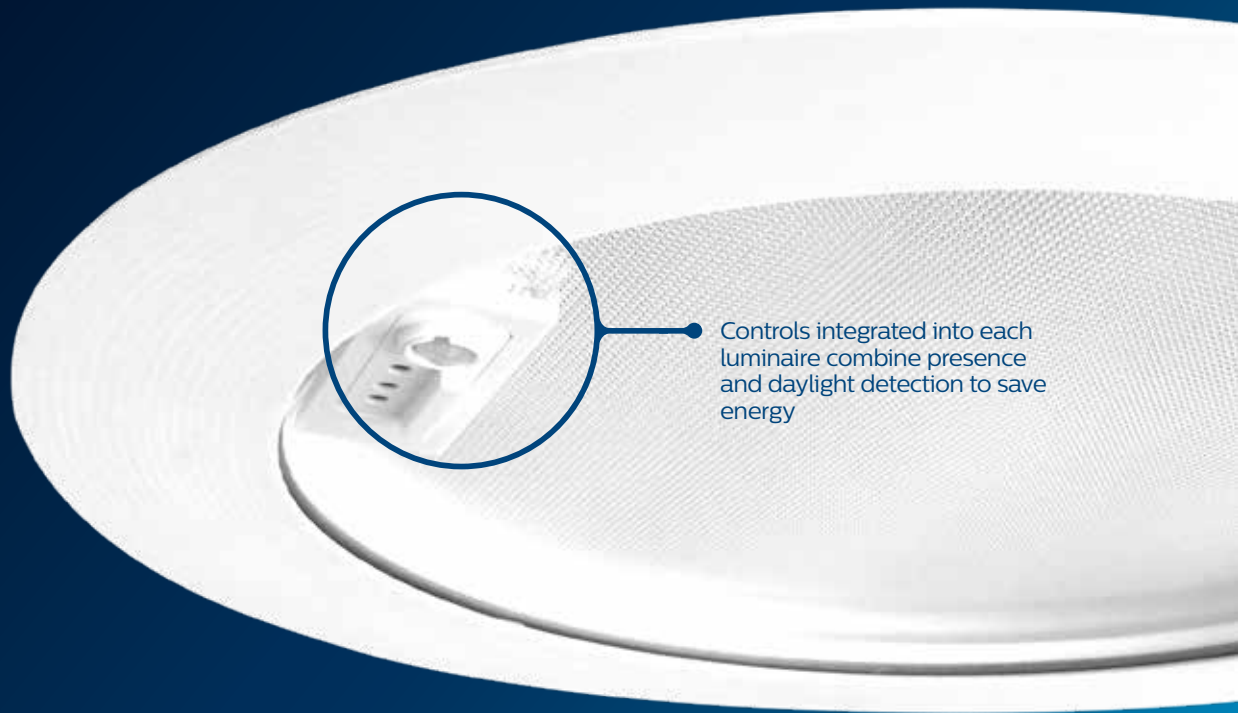

Controls integrated into each luminaire combine presence and daylight detection to save energy

# SpaceWise

Combine with our SpaceWise management system, an intuitive and flexible wireless management retrofit solution.

- Create tailor-made zones in your buildings
- Maximise energy savings
- Increase user comfort thanks to optimal light quality and personalised adjustment

[SpaceWise Configurator](#)



IR dongle  
for parameter setting  
644147 00



Android Application  
« Philips Field »



ON / OFF + Dimming or scene recall  
SpaceWise wireless / kinetic switches (no  
batteries required)  
2-button switch: 449 318 00  
4-button switch: 448 632 00





Be part of a  
**changing world**  
who recycles



**Visit the  
website**

[www.tailored.lighting.philips.com](http://www.tailored.lighting.philips.com)



Credits photos - ©Xavier Boymond, ©stock.adobe.com : ©srki66, ©Drobot Dean, ©Monkey Business, ©paulaphoto, ©Flamingo Images, ©rh2010

©2021 Signify Holding. All rights reserved. Signify reserves the right to make changes in specifications and/or to discontinue any product at any time without notice or obligation and will not be liable for any consequences resulting from the use of this publication.

UKI version April 2021